

**Item No.: SL650 Series**  
**(Power: 50w - 100w)**



## **Materials**

- High quality Die-casting aluminum alloy.
- Anodized and powder coated to assure the anti-corrosion performance.
- 3.5mm lead-free toughened glass with high light transmission.
- High power ceramic encapsulation multi-chip LED, Bridgelux Chip.

## **Features**

- Light distribution is similar to the bat wing, suitable for street lighting.
- Lamp's Efficiency: >85%, Power factor>0.95
- Patented technology for LED encapsulation (COB)
- Input voltage: AC 85V-265V (50-60Hz); DC24V (Available for solar energy system)
- Protection level: IP65, Insulation Class: CLASS 1.
- Lifespan: 50,000 hours, Lumens depreciation: <3% after 5000 hours
- Environment friendly, no UV
- GB7000.1, IEC60598, IEC61347, EN55015 test compliance.

## LED STREET LIGHT – SL650 SERIES (50W-100W)

### Drawing

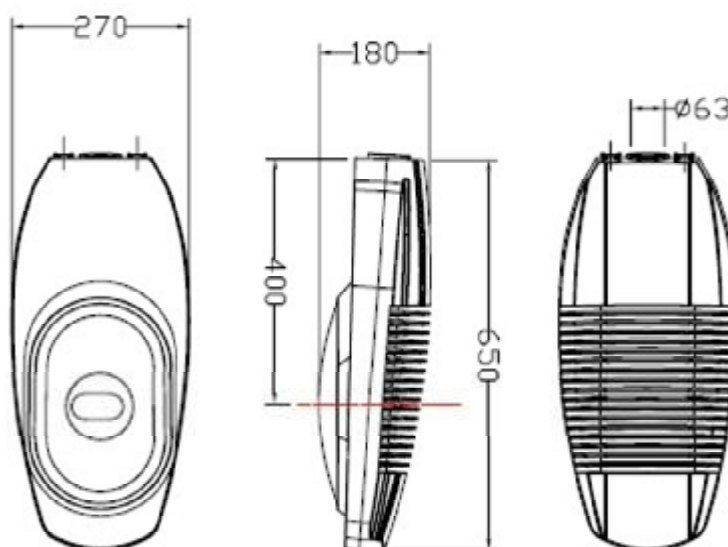

### Parameters

Input Voltage	AC85V-265V, DC24V(≤80W)	
Frequency Range	50Hz - 60Hz (AC)	
Total Harmonic Distortion	≤ 9 %	
Power Factor	> 0.9	
LED Quantity	1 pcs	
LED Power Consumption	50W - 100W	
LED Luminous Efficiency	100 LM/W; 130 LM/W	
Lamp's Efficiency	> 85 %	
Lighting Distribution Types	Type III	
Illuminance Uniformity	> 0.4	
Color Temperature (CCT)	WW	3000K - 3500K - 4000K
	PW	4500K - 5000K - 5500K
	CW	6000K - 6500K - 7000K
Color Rendering Index	WW	Ra> 75
	PW,CW	Ra> 78
Working Temperature	-40°C ~ +55°C	
Storage Temperature	-25°C ~ +65°C	
IP Grade	IP65	
Working Life-span	50,000h	
Color of Fixture	Grey	
Net Weight	10.3 kg	

# LED STREET LIGHT – SL650 SERIES (50W-100W)

## Road Surface Isolux Diagram (60w)

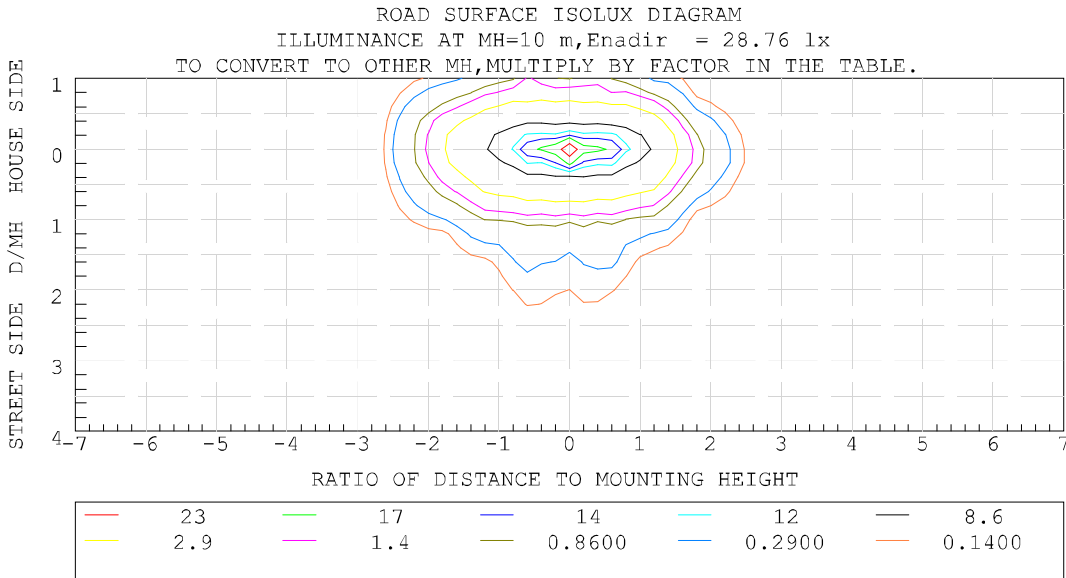

According to LB/T001-2008:  
 $U = E_{min}/E_{avg} = 0.120$   
 $E_{avg} = 10.32 \text{ lx}$

HEIGHT	FACTOR
5 m	4.000
6 m	2.778
7 m	2.041
8 m	1.563
9 m	1.235
10 m	1.000
11 m	0.826
12 m	0.694
13 m	0.592
14 m	0.510
15 m	0.444
16 m	0.391

## ISOCANDELA DIAGRAM

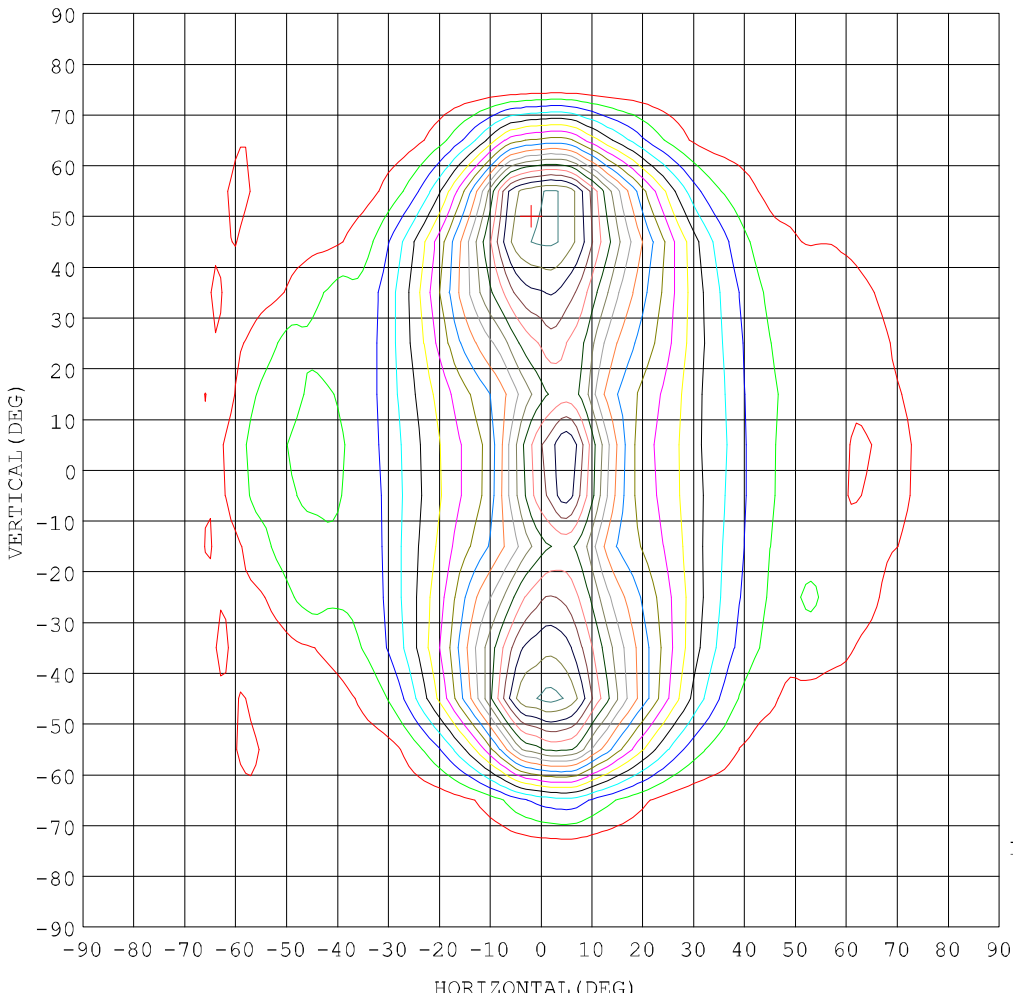

$I_{max}: 3144 \text{ (H-2.0, V50.0)}$

UNIT: cd

## Intensity Distribution Diagram (60w)

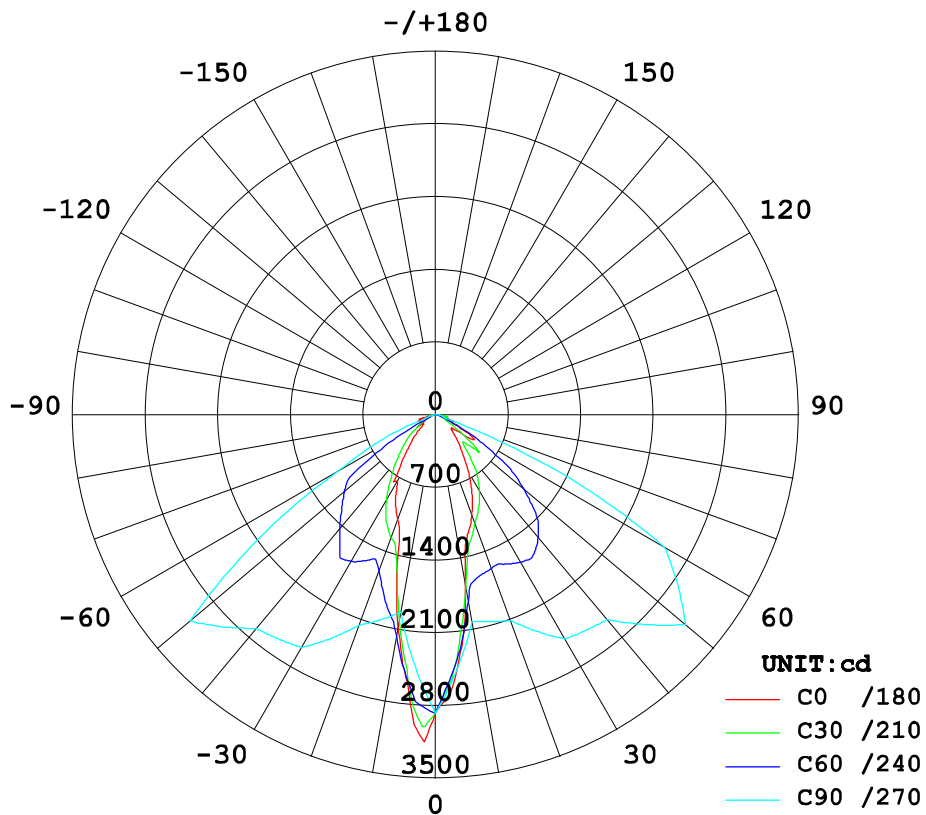

## Packing Info.

Package size: 78x22x33cm, 1 Piece/Carton, G.W.: 12 KGS

**FEEL**  
LIGHT FEELIGHT TECH CO., LIMITED

Tel: +86 755-33154377

Fax: +86 755-25828879

E-mail: [info@feellights.com](mailto:info@feellights.com)

<http://www.feellights.com>