

Item No.: HB420-150W (45°)

HB500S-150W (90°)

HB500B-150W (120°)



Materials

- High quality Die-casting aluminum alloy.
- Anodized and powder coated to assure the anti-corrosion performance.
- High power ceramic encapsulation multi-chip LED.
- High quality thermal conductive adhesive and other auxiliary materials.

Features

- Power Efficiency: >94%, Power factor>0.95
- Patented technology for LED encapsulation (COB)
- Input voltage: AC 85V-265V (50-60Hz)
- Protection level: IP65, Insulation Class: CLASS 1.
- Lifespan: 50,000 hours
- Environment friendly, no UV
- GB7000.1, IEC60598, IEC61347, EN55015 test compliance.

150W LED HIGH BAY

Drawing

45 degree Beam Angle

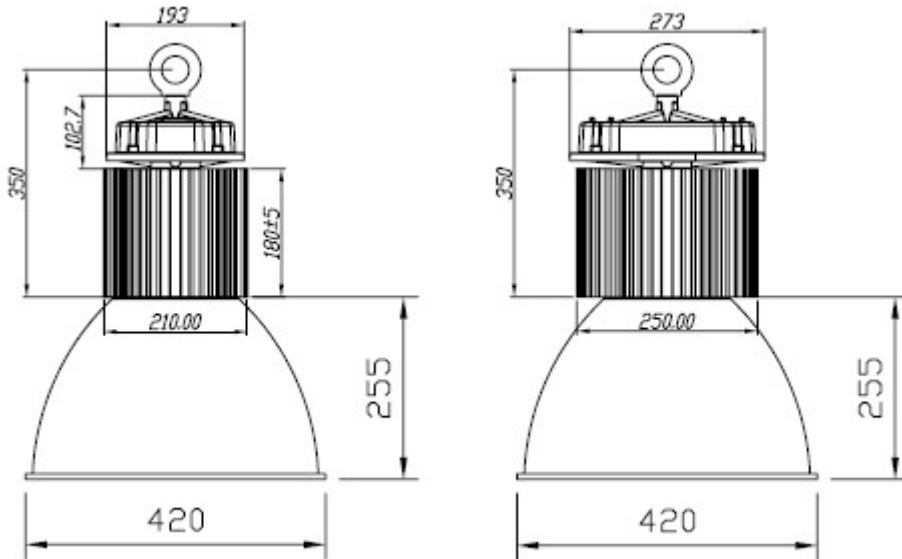

120 degree Beam Angle

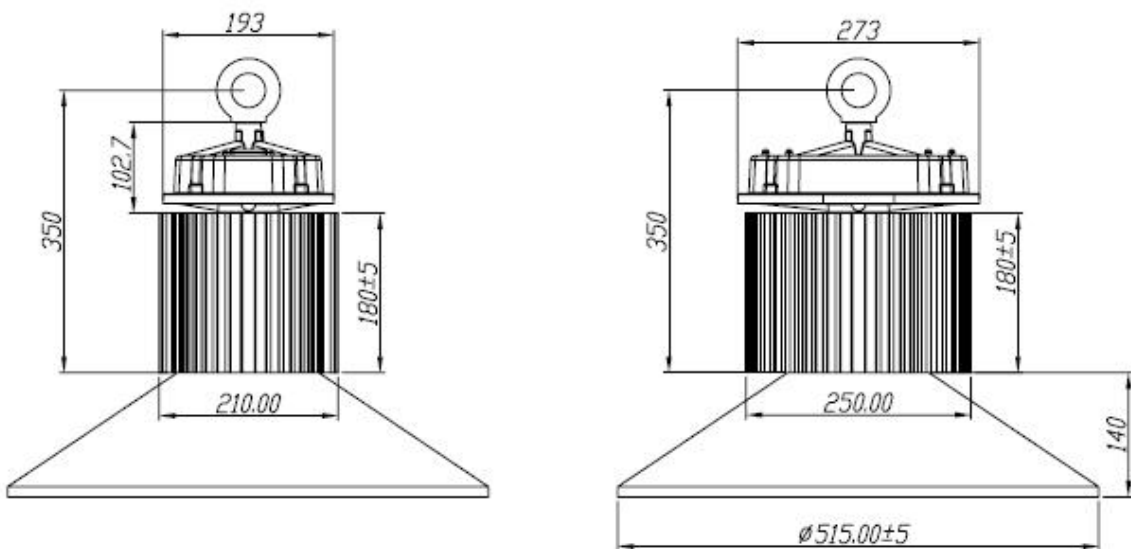

150W LED HIGH BAY

Parameters

Input Voltage	AC85V-265V	
Frequency Range	50Hz - 60Hz	
Total Harmonic Distortion	≤ 9 %	
Power Factor	> 0.9	
Power Efficiency	> 94 %	
LED Quantity	1 pcs	
LED Power Consumption	150W	
LED Luminous Efficiency	100LM/W; 130LM/W	
Illuminance Uniformity	> 0.4	
Color Temperature (CCT)	WW	2700K - 3200K - 3700K
	PW	4500K - 5000K - 5500K
	CW	6000K - 6500K - 7000K
Color Rendering Index	WW	Ra> 70
	PW,CW	Ra> 75
Working Temperature	-40°C ~ +55°C	
Storage Temperature	-25°C ~ +65°C	
IP Grade	IP65	
Working Life-span	50,000h	
Color of Fixture	Black, Silver	

150W LED HIGH BAY

Isolux Diagram (HB500B-150W, 100LM/W LED)

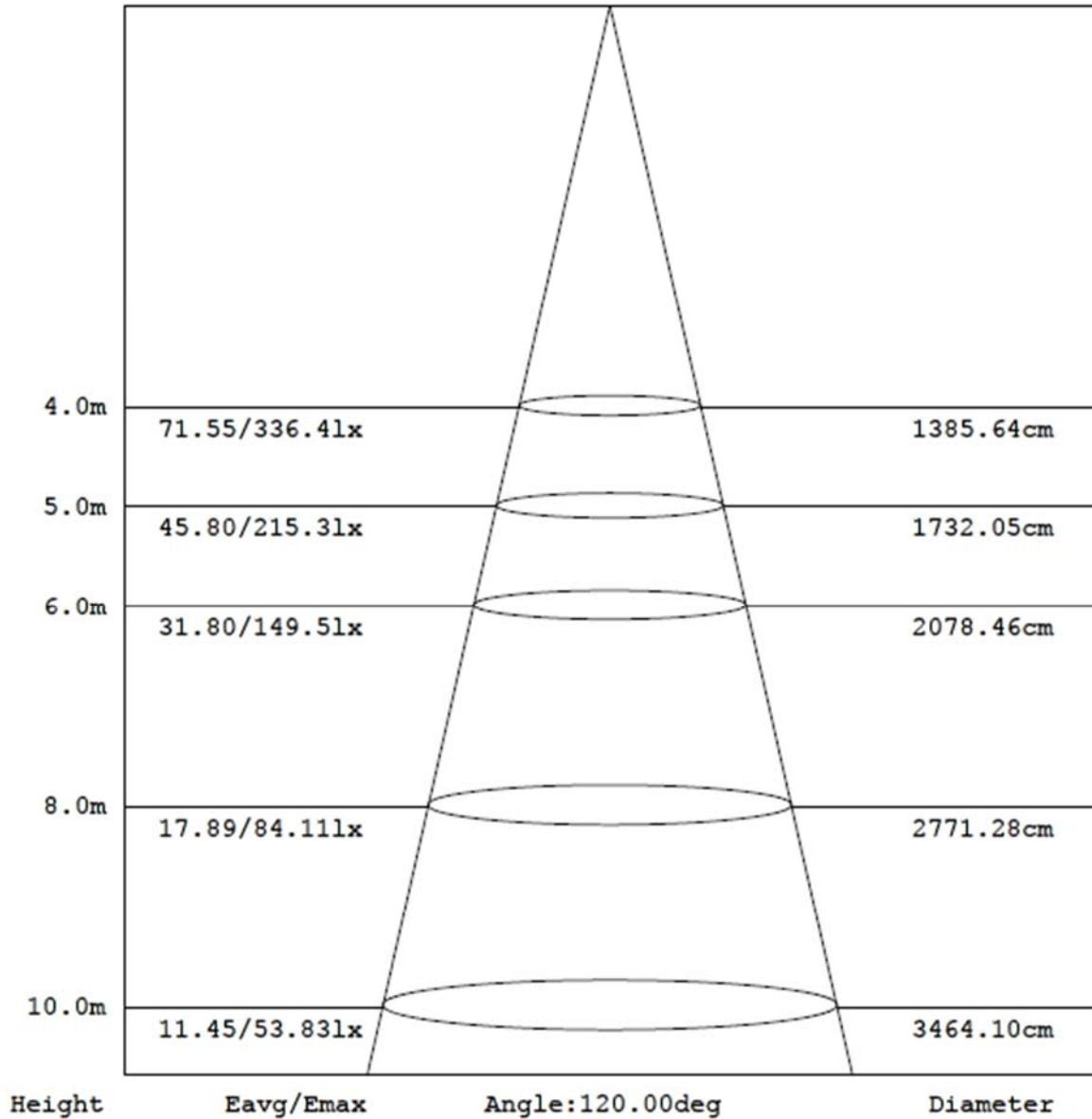

Note: The Curves indicate the illuminated area and the average illumination when the luminaire is at different distance.

150W LED HIGH BAY

Isolux Diagram (HB500B-150W, 100LM/W LED)

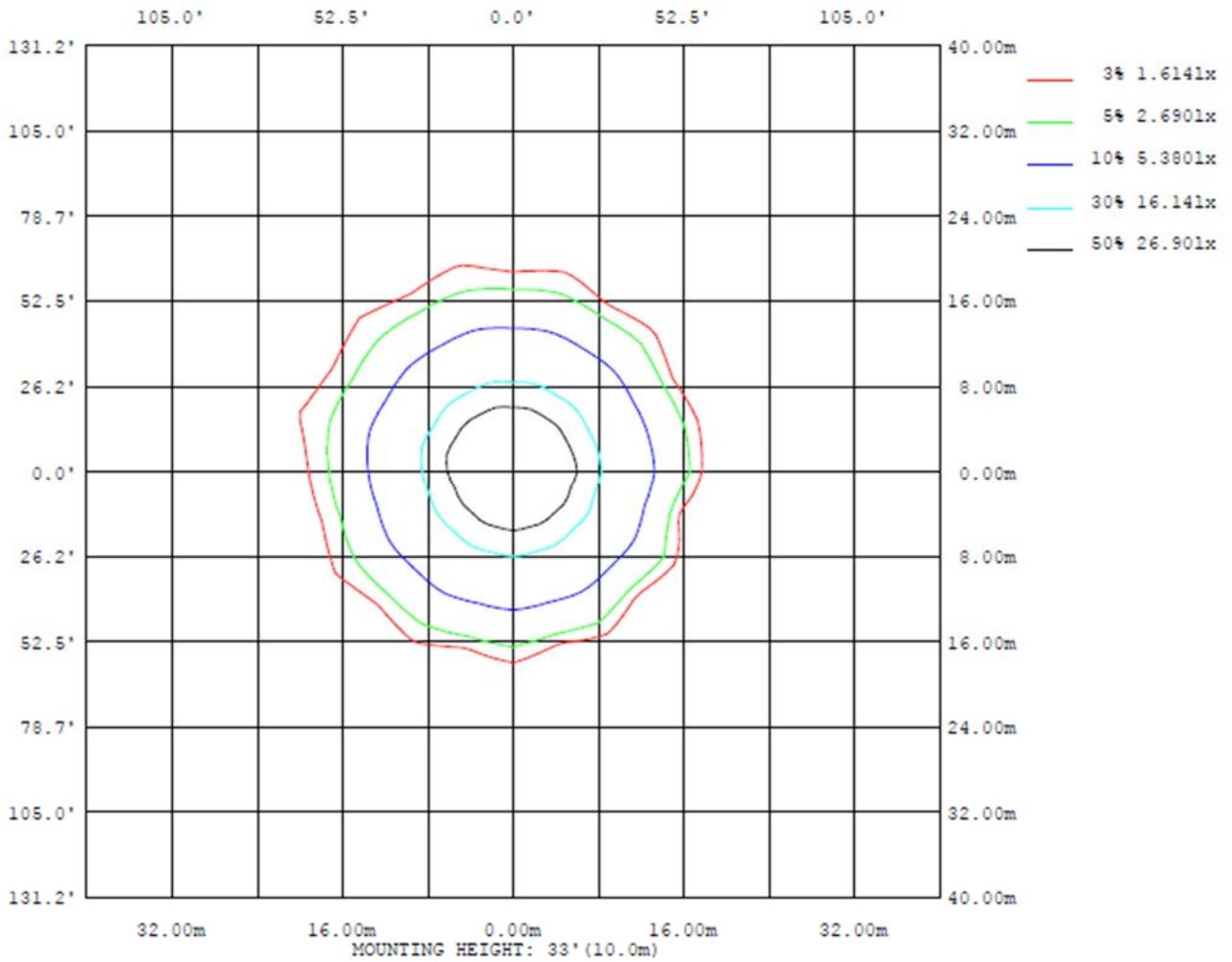

150W LED HIGH BAY

Luminous Intensity Distribution Diagram (HB500B-150W, 100LM/W LED)

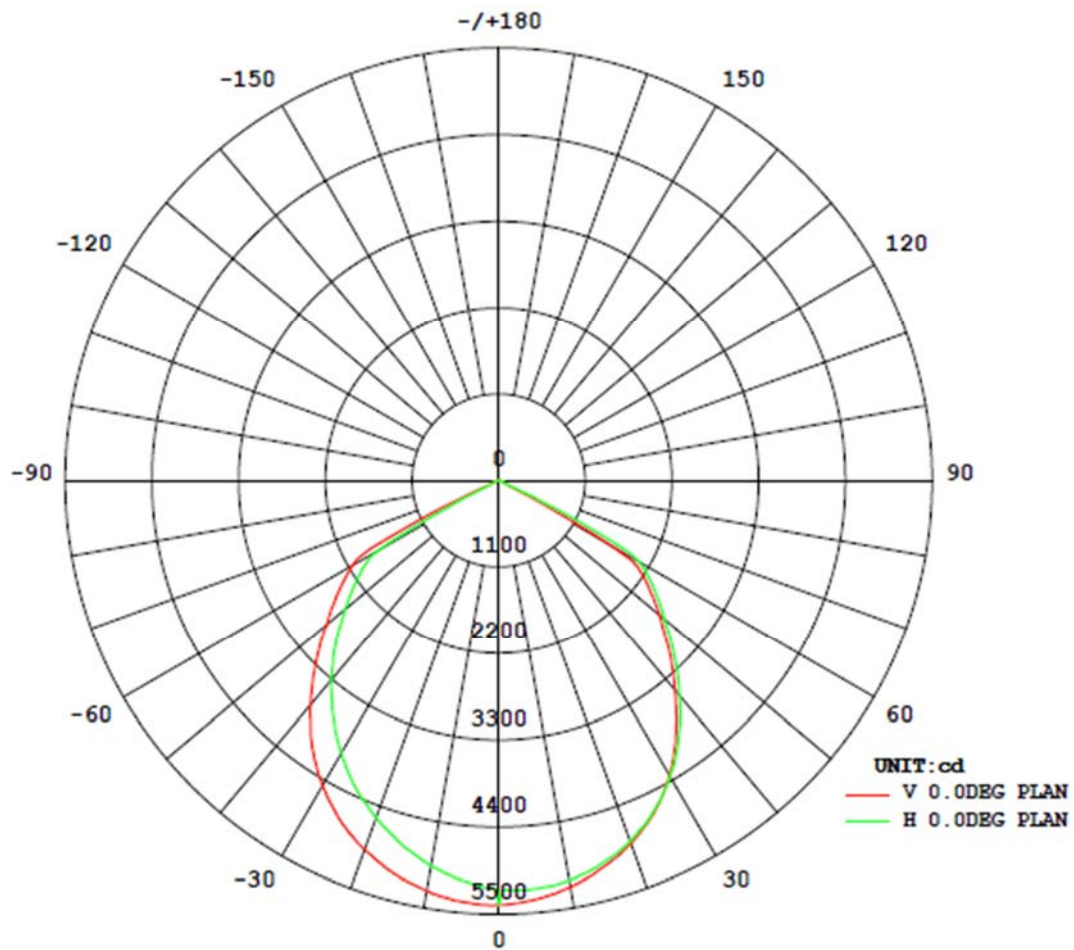

Packing Info.

- Heat sink:
Package size: 32x32x43cm, 1 PCS/Carton, G.W.: 10 KGS
- Reflectors:
45° Reflector: 50x50x55cm, 10PCS/Carton, G.W: 6.3 KGS
90° Reflector: 58x58x36cm, 10PCS/Carton, G.W: 7.8 KGS
120° Reflector: 58x58x31cm, 10PCS/Carton, G.W: 7.5 KGS

FEEL
LIGHT FEELIGHT TECH CO., LIMITED

Tel: +86 755-25828879
E-mail: info@feellights.com

Fax: +86 755-33154377
<http://www.feellights.com>

Copyright © FEELIGHT TECH CO., LIMITED All rights reserved.