

## **Item No.: FL295 Series**

**(Power: 60w - 80w)**



### **Materials**

- High quality Die-casting aluminum alloy.
- Anodized and powder coated to assure the anti-corrosion performance.
- High power ceramic encapsulation multi-chip LED.
- High quality thermal conductive adhesive and other auxiliary materials.

### **Features**

- Power Efficiency: >87%, Power factor>0.95
- Patented technology for LED encapsulation (COB)
- Input voltage: AC 85V-265V (50-60Hz); DC24V (Available for solar energy system)
- Protection level: IP65, Insulation Class: CLASS 1.
- Lifespan: 50,000 hours
- Environment friendly, no UV
- GB7000.1, IEC60598, IEC61347, EN55015 test compliance.

## LED FLOOD LIGHT – FL295 SERIES (60-80W)

### Drawing

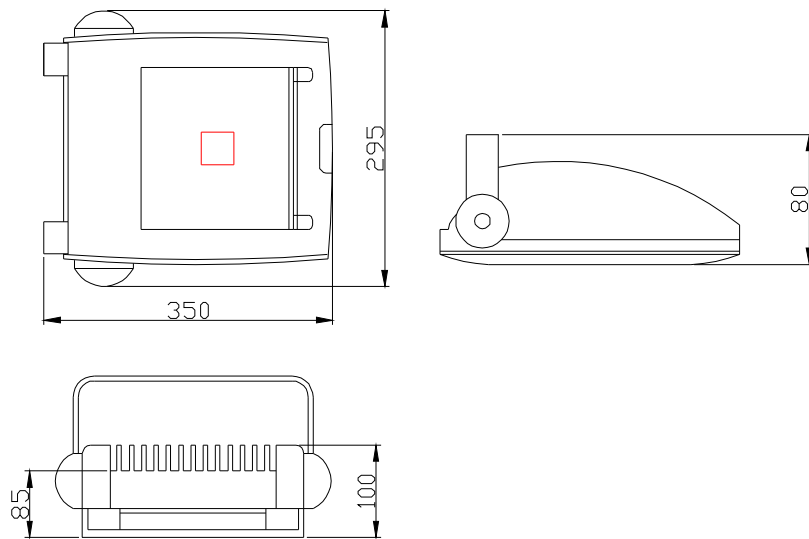

### Parameters

Input Voltage		85V-265Vac, 24Vdc
Frequency Range		50Hz - 60Hz (AC)
Total Harmonic Distortion		≤ 9 %
Power Factor		> 0.95
LED Quantity		1 pcs
LED Power Consumption		60W - 80W
LED Luminous Efficiency		100 LM/W; 130 LM/W
Lamp's Efficiency		> 87 %
Illuminance Uniformity		> 0.4
Color Temperature (CCT)	WW	2700K - 3200K - 3700K
	PW	4500K - 5000K - 5500K
	CW	6000K - 6500K - 7000K
Color Rendering Index	WW	Ra > 70
	PW,CW	Ra > 75
LED Junction Temperature		≤ 80°C
Working Temperature		-40°C ~ +55°C
Storage Temperature		-25°C ~ +65°C
IP Grade		IP65
Working Life-span		50,000h
Color of Fixture		Grey, Black, White

# LED FLOOD LIGHT – FL295 SERIES (60-80W)

## Isolux Diagram (FL295-60W)

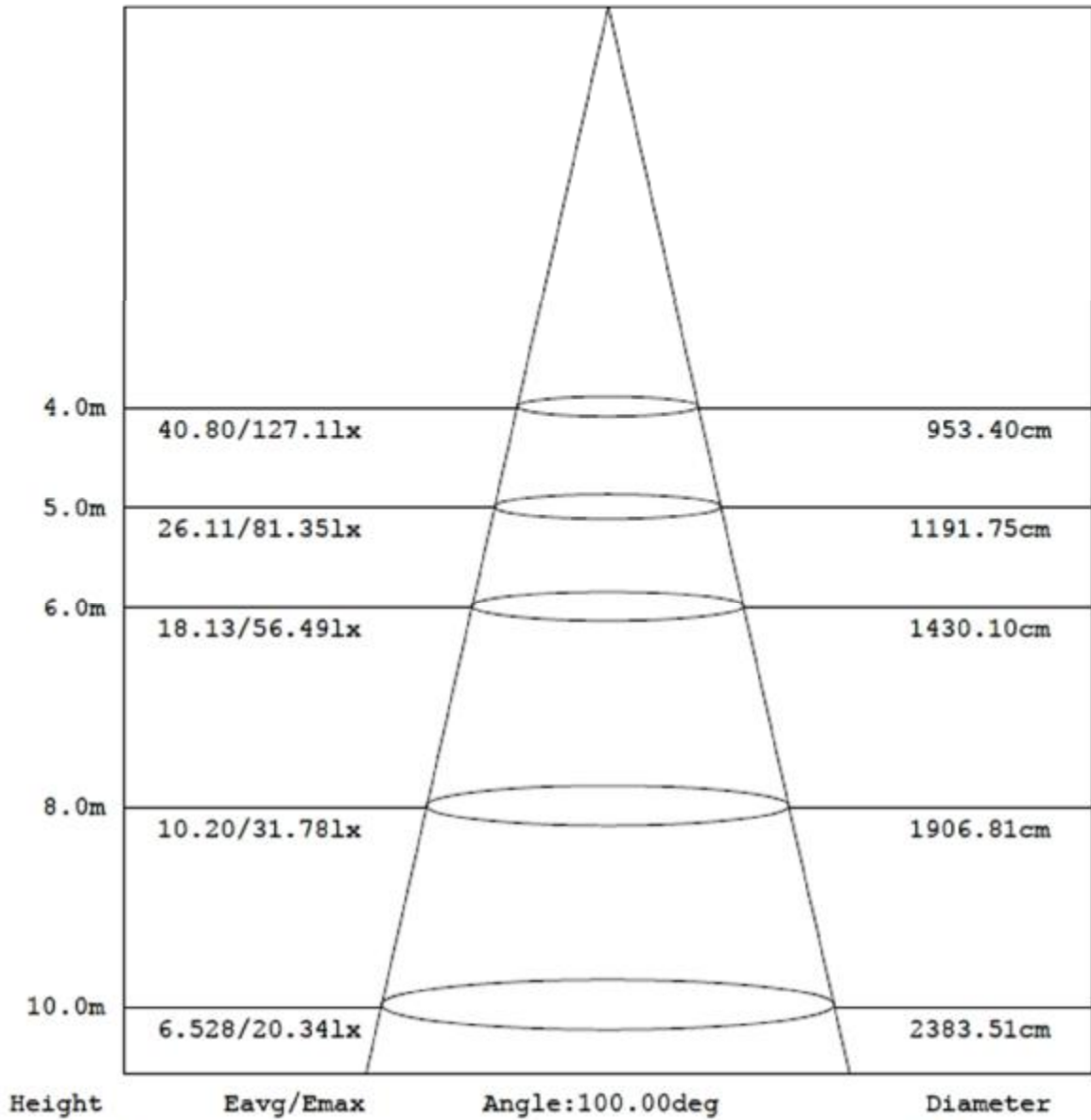

Note: The Curves indicate the illuminated area and the average illumination when the luminaire is at different distance.

# LED FLOOD LIGHT – FL295 SERIES (60-80W)

## Isolux Diagram (FL295-60W)

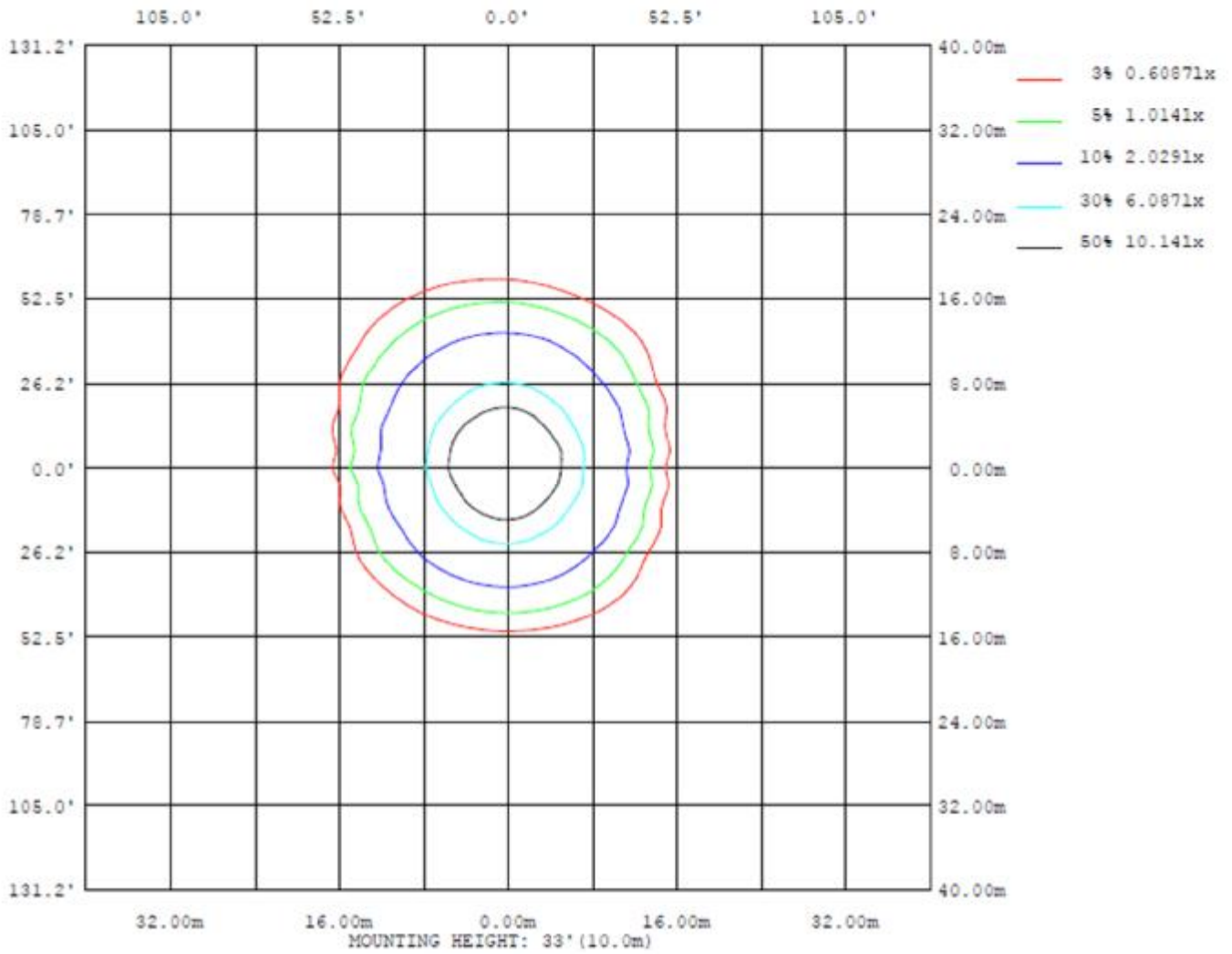

## Luminous Intensity Distribution Diagram (FL295-60W)

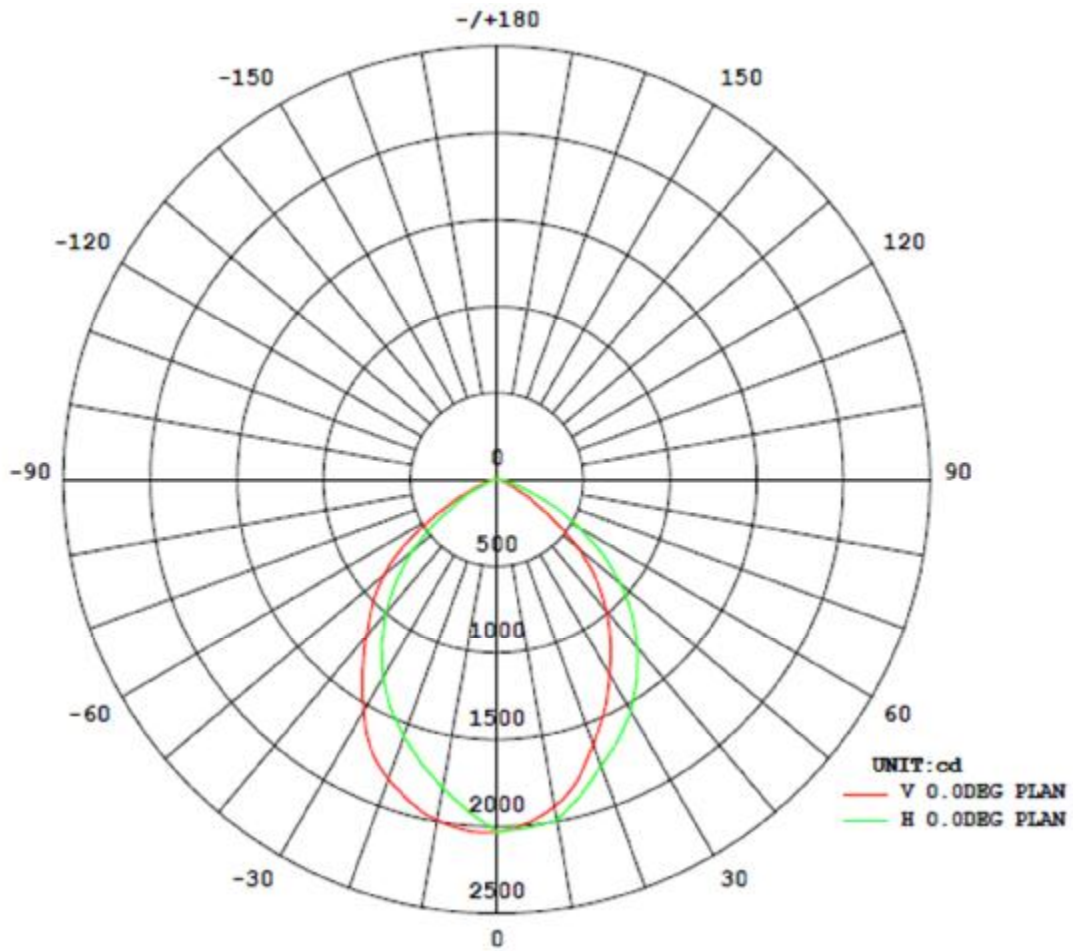

## Packing Info.

Package size: 49x34x12cm, 2 PCS/Carton, G.W.: 11.62 KGS

**FEEL**  
LIGHT FEELIGHT TECH CO., LIMITED

Tel: +86 755-2582 8879

Fax: +86 755-3315 4377

E-mail: [info@feellights.com](mailto:info@feellights.com)

<http://www.feellights.com>